

Black TM Stump Products

Gawler TM Feature Wall System

Installation Guide

1. PREPARE THE FOUNDATION

Measure and mark out the location of the wall. Excavate the base trench approximately 400mm wide and approximately 300mm deep for the length and layout of the wall. Start the excavation at the lowest level and step up in 150mm graduations as required. Board up any sections of trench if necessary to screed a level top. Mix and pour the concrete into the trench, placing the deformed bar as the concrete is placed. While the concrete is green, push in some short lengths of reo bar at the spacing of the centre holes in the blocks as starter bars.

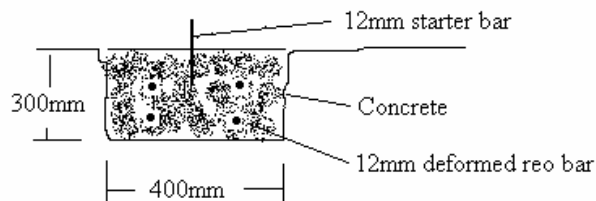

2. BASE COURSE INSTALLATION

This is the most important course of the wall as the rest of the wall relies upon it. Accuracy is critical for a well constructed good looking wall. Spread a thin layer of mortar or tile adhesive across the foundation (thick enough to level off from the foundation variations). Place the first course of **Gawler** TM blocks abutting one another on the prepared base, tapping them down with a rubber mallet to ensure a good bedding.

Ensure each block is level, end to end, back to front. Use a string line for alignment of straight walls or PVC conduit bent around for curved walls.

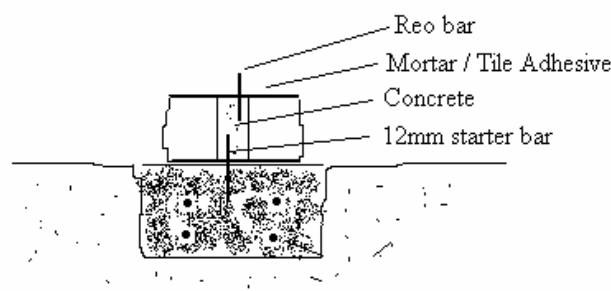

3. ADDITIONAL COURSES

Fill the block cavities from the previous course, with concrete. If desired spread a thin layer of mortar mix or tile adhesive on the top of the previous blocks, (note:- this is not essential though) . Place the next course of **Gawler™** blocks on top of the first, ensure the blocks butt together and except for when using the 150V or 300V vertical blocks the joints should not run in line. Insert reo bars into the block cavities and push them down into the concrete filled cavity of the previous block, ensuring half of the rod length is inserted. Continue the process as you work up the wall.

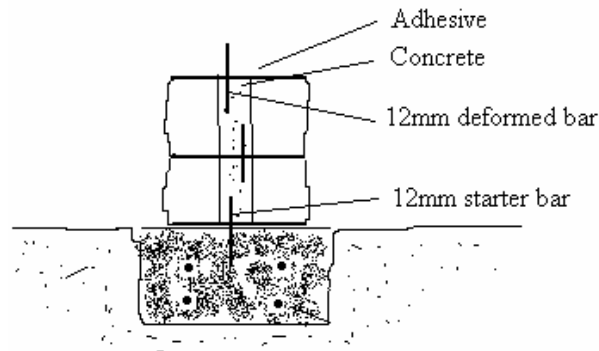

4. MIXING and MATCHING BLOCKS

Under most circumstances to provide the best look and at the same time a strong, robust wall, the wall should be constructed mostly of **Gawler™** 300 and 450 series blocks with some 150 series blocks amongst them.

The **Gawler™** 150V are to provide a more interesting random pattern, always stagger these blocks throughout the wall construction. As a guide, one **Gawler™** 150V per every second course at least two linear metres apart.

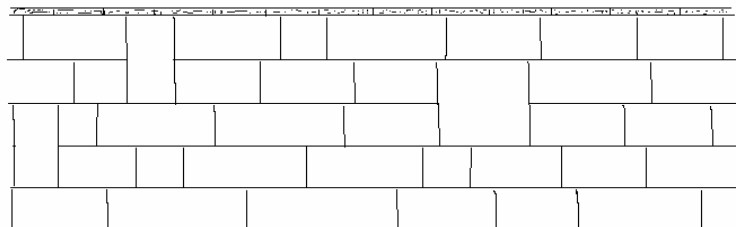

5. CAPPING THE WALL

Clean off the top of the last course after filling the cavity. For the best results a mortar mix of 1 part cement to 4 parts sand will allow you to level the top capping and remove any slight level variations to the top blocks that may have occurred during the course of construction. Starting at the lowest point, tap the capping stone gently down into the mortar base, allowing overhang of the capping on both sides of the wall and ensuring the capping block is level end to end, front to back.

Hint:- For lighter coloured blocks use Brightonlite cement rather than grey Normal Portland. A colour oxide may be added to the mix if so desired.